

2 0 2 6
C A T Á L O G O

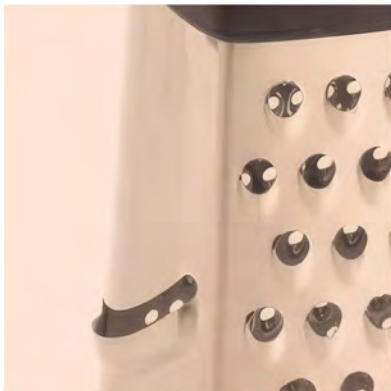

WECK.





Produtos de Alumínio

Os produtos metálicos são desenvolvidos em alumínio injetado, um processo sem soldas, que permite excelente resultado, durabilidade e precisão.

A linha colorida recebe pintura eletrostática/epóxi atóxica, podendo ter contato com alimentos, um acabamento mais duro e resistente do que a pintura tradicional, sem bolhas ou escorrimientos, com alto brilho.

Um processo diferenciado de produção e pintura com relação ao que existe no mercado, garantindo um produto inovador e único.

Produtos de Silicone

Seguindo as cores da moda, os utensílios são desenvolvidos com um silicone altamente resistente, que suporta até 240°C.

Todos os produtos são atóxicos e resistem a mudanças de temperatura sem deformar e aquecer.

Como não absorvem líquidos, resíduos ou cheiro, são higiênicos e fáceis de lavar.

Uma solução prática e moderna, que traz toda funcionalidade sem danificar o fundo das panelas ou recipientes.

NÃO CONTÉM BISFENOL A.

Produtos em Nylon

Os utensílios em nylon oferecem um custo inferior ao silicone e apresentam inúmeros benefícios, como: resistência a altas temperaturas (até 200°C), podem ir à máquina de lavar louças e permanecem bonitos por bastante tempo.

São muito indicados para uso em produtos com revestimento antiaderente, não arranhando-os.

A linha da Weck conta com grande variedade de utensílios, nas cores que são tendência em cozinha, unindo beleza e praticidade.

NÃO CONTÉM BISFENOL A.

Produtos em Aço Inox

A linha de utensílios em Aço Inox foi concebida para simplificar e facilitar as atividades culinárias, englobando boleadores, raladores diversos, descascadores e uma infinidade de opções.

Desenvolvidos com design diferenciado e anatômico, aliado à matéria prima de alta qualidade, resistente e durável, trazem beleza e praticidade à cozinha.

Grande parte dos itens conta ainda com o cabo soft touch, nas cores da atual tendência, agregando ainda mais conforto e modernidade.

Sumário

CLIQUE EM UMA DAS CATEGORIAS ABAIXO

04

LINHA
Melamina

15

LINHA
Monet

16

LINHA
Cubas

18

LINHA
Profissional

36

LINHA
Bar

41

LINHA
Formas de Silicone

42

LINHA
Diversos

46

LINHA
Vidro

47

LINHA
Bandejas

48

LINHA
Facas

49

LINHA
Espátulas

51

LINHA
Silicone

52

LINHA
Creme

53

LINHA
Cinza

54

LINHA
Preta

56

LINHA
Polida

57

LINHA
Assadeiras

58

LINHA
Fogão

Inovação, know how e criatividade. Foram essas matérias-primas que deram origem à Weck Utilidades Domésticas.

Com uma equipe altamente especializada, inovadores processos de produção e um conceito diferenciado, a Weck revolucionou

o mercado, trazendo as cores da moda aos acessórios de cozinha, em uma combinação perfeita de beleza e funcionalidade.

Com um rigoroso processo de qualidade, os produtos são constantemente renovados, trazendo o que há de mais atual sempre!

Porque **Design** vai muito além!



Travessa Marmorizada 24 x 14 cm
código 6613



Travessa Marmorizada 32 x 13 cm
código 6614



Frigideira Marmorizada Com bicos
Laterais 25 x 17 cm | código 6615



Panelinha Marmorizada
27 x 15 cm | código 6616



Travessa Dupla
Marmorizada 36 x 10 cm
código 6617



Cumbuca 10 x 5 cm - 210ml
código 6633



Tigela Empilhável 12 x 4,4 cm
250ml | código 6636



Cumbuca 11,3 x 6 cm - 300ml
código 6634



Tigela Empilhável 14,3 x 4,8 cm
470ml | código 6637



Cumbuca 12,7 x 6,7 cm - 470ml
código 6635



Tigela Empilhável 16,5 x 5,5 cm
650ml | código 6638

100%
MELAMINA



Não usar no micro-ondas, na chama direta ou no forno | Suporta de -20°C a +70°C por até 2h





Ramekin 6,7 x 3,7 cm
60ml | código 6618



Ramekin 7,2 x 4 cm
100ml | código 6619



Ramekin 8,5 x 4,5 cm
140ml | código 6620



Ramekin 9,4 x 5 cm
180ml | código 6621



Finger Food Barquete
12,8 x 7 x 2,8 cm - 60ml
código 6622



Finger Food Porta Shoyu
10 x 6,6 x 2,4 cm - 50ml
código 6623



Finger Food Folha
9,5 x 7,8 x 3,2 cm - 62ml
código 6624



Finger Food Redondo
9,7 x 3 cm - 125ml
código 6625



Finger Food Gota
10,2 x 8,8 x 4 cm
120ml | código 6628



Finger Food Manteigueira
7,9 x 2,7cm - 38ml
código 6627



Finger Food Quadrado
8,8 x 8,4 x 3,5 cm - 90ml
código 6626



Finger Food Mini Empilhável
5,6 x 2,3 cm - 30ml | código 6630



Finger Food Ovalado
10,2 x 9,2 x 3,7 cm - 125ml
código 6629



Finger Food Colher 10 x 5,8 x 3 cm
30ml | código 6631



Finger Food Colher 14 cm
30ml | código 6632

100%
MELAMINA



Não usar no micro-ondas, na chama direta ou no forno | Suporta de -20°C a +70°C por até 2h





Travessa Retangular Funda
22,6 x 14,5 x 5,7 cm | código 6600



Travessa Retangular Funda
30 x 22,5 x 5,7 cm | código 6601

Travessa Retangular Funda
40 x 27,5 x 5 cm
código 6602



Travessa Gourmet
25 x 15 x 7 cm | código 6604



Travessa Gourmet
35 x 25 x 7 cm | código 6605



Travessa Gourmet
45 x 30 x 7 cm
código 6606

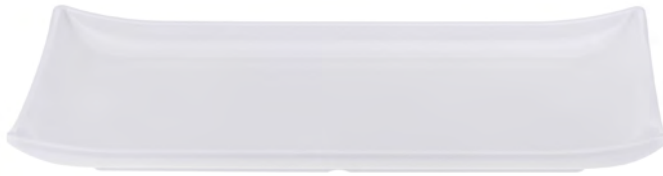

Travessa Retangular com Canto
26 x 14,8 x 2,3 cm | código 6647

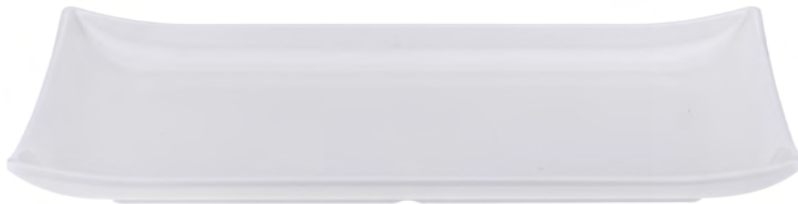

Travessa Retangular com Canto
31,2 x 17,6 x 2,8 cm
código 6648



Travessa Retangular
com Canto
36,4 x 20,2 x 3,3 cm
código 6649

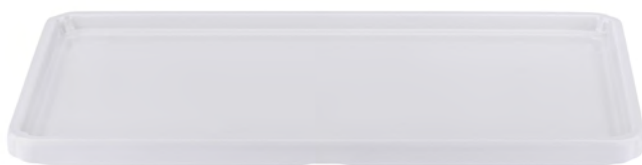

Travessa Retangular Empilhável c/ Rebaixo
27 x 15,2 x 1,4 cm | código 6650

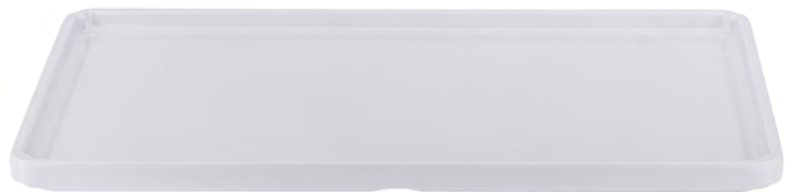

Travessa Retangular Empilhável c/ Rebaixo
32 x 18 x 1,5 cm | código 6651

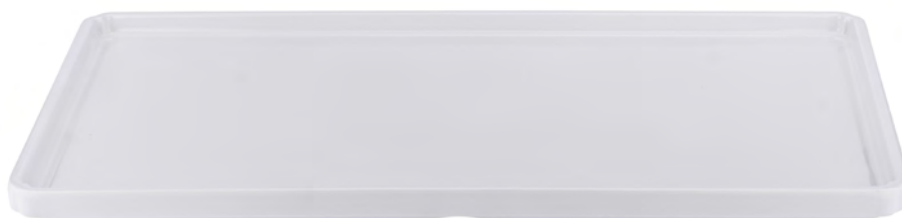

Travessa Retangular Empilhável c/ Rebaixo
37 x 21 x 1,6 cm | código 6652

100%
MELAMINA



Não usar no micro-ondas, na chama direta ou
no forno | Suporta de -20°C a +70°C por até 2h





Travessa Retangular Rasa
16,7 x 10,5 x 1,6 cm | código 6658



Travessa Retangular Rasa
19 x 12,5 x 2 cm | código 6659



Travessa Retangular Rasa
21,7 x 14,2 x 2 cm | código 6660



Travessa Retangular Rasa
24,2 x 15,5 x 2,4 cm | código 6661

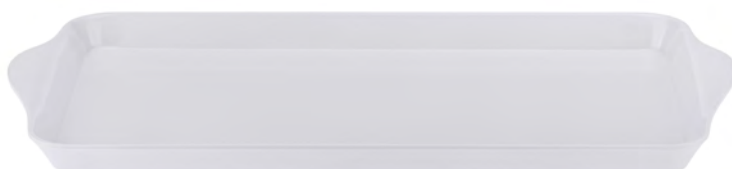

Bandeja Retangular
30,5 x 15 x 2,2 cm | código 6662

Bandeja Retangular
38 x 16 x 2,6 cm
código 6663

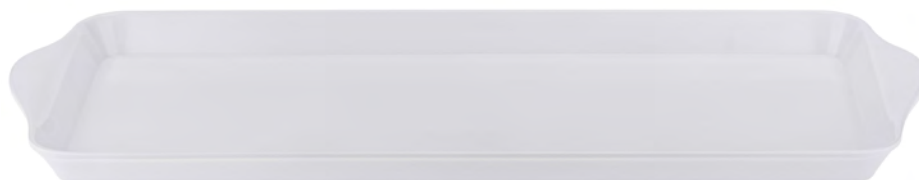



Barco 26 x 21 x 4,2 cm
código 6603



Petisqueira 28 cm
código 6664

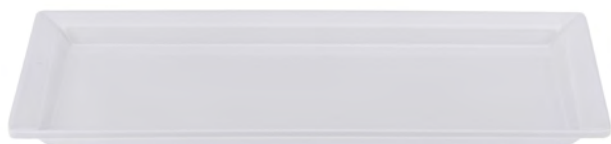

Travessa Retangular
24 x 13,4 x 1,4 cm | código 6644

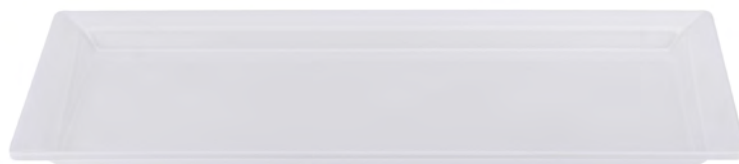

Travessa Retangular
29 x 16 x 1,5 cm | código 6645

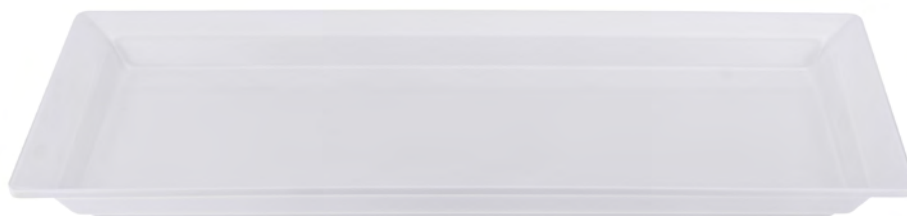

Travessa Retangular 35 x 19,7 x 2,4 cm
código 6646

100%
MELAMINA



Não usar no micro-ondas, na chama direta ou
no forno | Suporta de -20°C a +70°C por até 2h





Saladeira Redonda c/ Alça
25 x 5,6 cm | código 6653



Saladeira Redonda Ondulada
24,8 x 6,2 cm | código 6655



Saladeira Redonda c/ Alça
30 x 6,8 cm | código 6654



Saladeira Redonda Ondulada
30 x 7,2 cm | código 6656



Saladeira Florata 35 x 8,5 cm
código 6657



Saladeira Flower 28 cm | código 6610



Saladeira Quadrada
10,2 x 4,9 cm - 240ml
código 6639



Saladeira Quadrada
14 x 4,4 cm - 410ml
código 6640



Saladeira Quadrada
16 x 5 cm - 610ml
código 6641



Saladeira Quadrada
18,4 x 5,8 cm - 970ml código 6642



Saladeira Quadrada
25 x 10 cm - 4000ml
código 6643

100%
MELAMINA



Não usar no micro-ondas, na chama direta ou no forno | Suporta de -20°C a +70°C por até 2h





Saladeira Oval
18 x 12 x 4,2 cm
código 6607



Tigela Retangular
20,3 x 13,4 x 4,5 cm - 450ml
código 6611



Saladeira Oval
22 x 14 x 4,8 cm
código 6608



Tigela Retangular
22,7 x 15 x 5 cm - 700ml
código 6612



Saladeira Oval
24 x 19 x 7 cm
código 6609



Faca de
Sobremesa
21 cm Monet
código 6124

Faca de
Mesa 23 cm
Monet
código 6121

Faca de
Churrasco
23 cm Monet
código 6120



Garfo de
Sobremesa 19 cm
Monet | código 6126

Garfo de Mesa
20 cm Monet
código 6123



Faqueiro Aço Inox
24 Peças Monet
código 6129



Colher de
Café 11 cm
Monet
código 6128

Colher de
Chá 14 cm
Monet
código 6127

Colher de
Sobremesa
18 cm Monet
código 6125

Colher de
Mesa 20 cm
Monet
código 6122

Cubas



IR PARA O
SUMÁRIO

Cubas 1/1 530 x 325 mm



CUBA COM ALÇA

sku	profundidade	capacidade
6562	200 mm	24,3 Litros
6563	150 mm	19,5 Litros
6564	100 mm	13 Litros
6565	65 mm	8,6 Litros

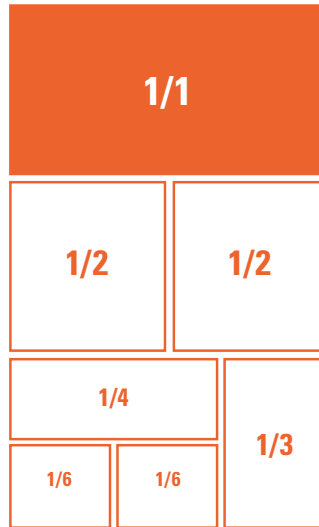

CUBA sem ALÇA

sku	profundidade	capacidade
6557	100 mm	13 Litros
6558	65 mm	8,6 Litros
6559	40 mm	5 Litros
6560	20 mm	2 Litros

Cubas 1/3 325 x 175 mm

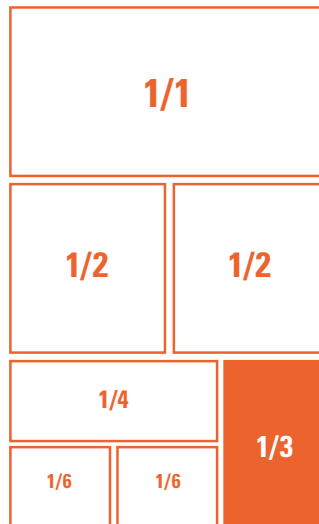

CUBA SEM ALÇA

sku	profundidade	capacidade
6575	150 mm	5,4 Litros
6576	100 mm	3,6 Litros
6577	65 mm	2,4 Litros

Cubas 1/6 176 x 163 mm

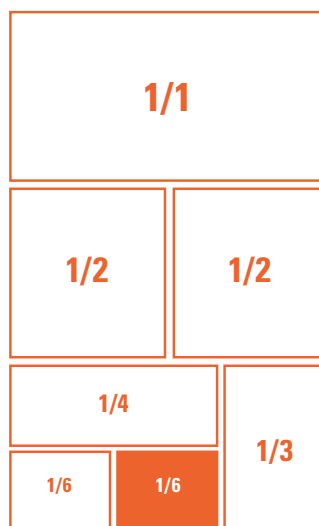

CUBA SEM ALÇA

sku	profundidade	capacidade
6582	150 mm	2,2 Litros
6583	100 mm	1,6 Litros
6584	65 mm	1 Litro



Cubas 1/2 325 x 265 mm



CUBA COM ALÇA

sku	profundidade	capacidade
6571	200 mm	11,4 Litros
6572	150 mm	8,8 Litros
6573	100 mm	5,8 Litros

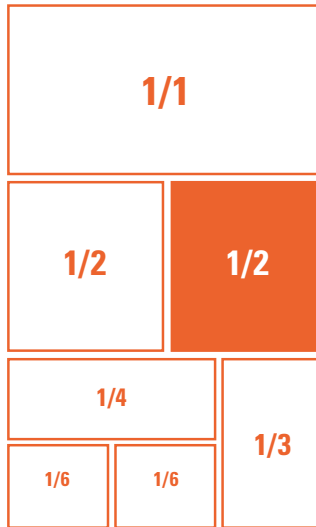

CUBA SEM ALÇA

sku	profundidade	capacidade
6567	150 mm	8,8 Litros
6568	100 mm	5,8 Litros
6569	65 mm	3,9 Litros

Cubas 1/4 265 x 162 mm

CUBA SEM ALÇA

sku	profundidade	capacidade
6579	100 mm	2,6 Litros
6580	65 mm	1,6 Litros

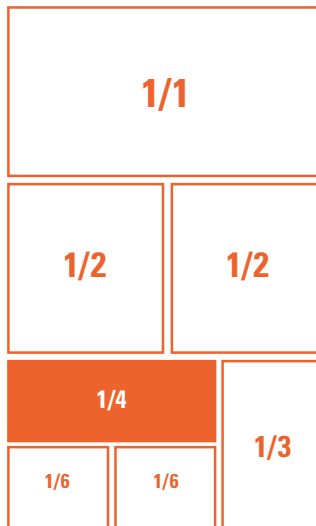

Tampas



TAMPA COM RECORTE

sku	tamanho	cuba
6566	530 x 325 mm	1/1
6574	325 x 265 mm	1/2



TAMPA SEM RECORTE

sku	tamanho	cuba
6561	530 x 325 mm	1/1
6570	325 x 265 mm	1/2
6578	325 x 176 mm	1/3
6581	265 x 162 mm	1/4
6585	176 x 163 mm	1/6



Assadeira/Travessa Alumínio
Antiaderente 38 x 15 x 7 cm Preta
código 3220



Assadeira/Travessa Alumínio
Antiaderente 23 x 15 x 7 cm Preta
código 3200



Assadeira/Travessa Alumínio Antiaderente
38 x 23 x 7 cm Preta | código 3230



Assadeira/Travessa Alumínio
Antiaderente 23 x 23 x 7 cm Preta
código 3210

Assa / Cozinha / Serve • Prática / Fácil Limpeza / Durabilidade



Alumínio revestido em
antiaderente de alta performance



FORNO / GRILL



GÁS



ELÉTRICO



LAVA-LOUÇAS



Assadeira/Travessa Alumínio
Antiaderente 23 x 15 x 7 cm
Vermelha | código 3202



Assadeira/Travessa Alumínio
Antiaderente 38 x 15 x 7 cm
Vermelha | código 3222



Assadeira/Travessa Alumínio
Antiaderente 23 x 23 x 7 cm
Vermelha | código 3212



Assadeira/Travessa Alumínio Antiaderente
38 x 23 x 7 cm Vermelha | código 3232



Elabore sua pista

Você consegue compor diversas pistas usando todos os tamanhos e cores das assadeiras



Pá Perfurada para Girar Pizza
Inox 23 cm c/ Cabo em Alumínio
Azul 142 cm | código 5740



Pá para Enfornar Pizza
Alumínio Anodizado 30,5 x
35,5 cm c/ Cabo em Alumínio
Azul Curto | código 5743



Pá para Enfornar Pizza
Alumínio Anodizado 35,5 x
40,5 cm c/ Cabo em Alumínio
Azul Curto | código 5744



Pá para Enfornar Pizza
Alumínio Anodizado 30,5 x 35,5 cm
c/ Cabo em Alumínio Azul 120 cm
código 5745

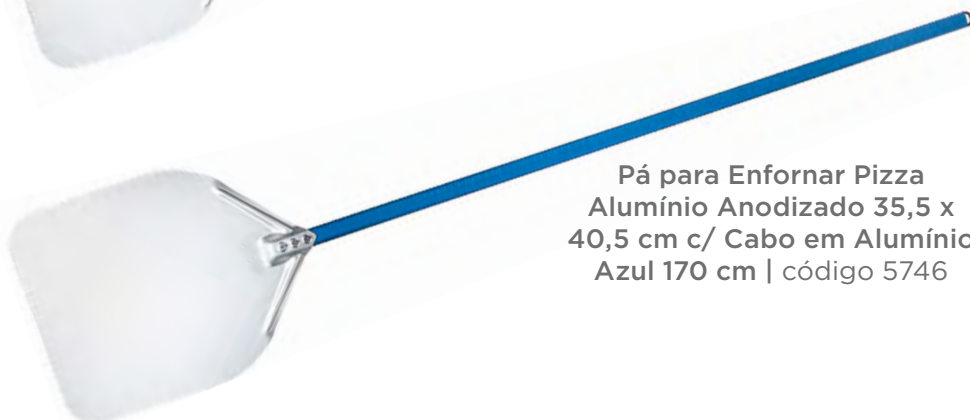

Pá para Enfornar Pizza
Alumínio Anodizado 35,5 x
40,5 cm c/ Cabo em Alumínio
Azul 170 cm | código 5746

Cortador de Pizza Profissional
Lâmina 10 cm Aço Inox e
Cabo Azul código 5755



Escova Limpeza de Forno c/ Raspadora e Cabo em Alumínio Azul 170 cm | código 5750



Pá Perfurada p/
Enfornar Pizza
Alumínio Anodizado
30,5 x 35,5 cm c/ Cabo
em Alumínio Azul Curto
código 5751



Pá Perfurada p/
Enfornar Pizza
Alumínio Anodizado
35,5 x 40,5 cm c/ Cabo
em Alumínio Azul Curto
código 5752



Pá Perfurada p/ Enfornar
Pizza Alumínio Anodizado
30,5 x 35,5 cm c/ Cabo
em Alumínio Azul 120 cm
código 5753



Pá Perfurada p/ Enfornar
Pizza Alumínio Anodizado
35,5 x 40,5 cm c/ Cabo
em Alumínio Azul 170 cm
código 5754





Botijão Térmico
Inox 10 Litros
código 6524



Botijão Térmico
Inox 8 Litros
código 6523



Torneira Plástica
para Botijão
Térmico
código 6525



Botijão Térmico
Inox 6 Litros
código 6522



Botijão Térmico
Inox 4 Litros
código 6521



Garrafa Térmica Profissional
Inox 2.5 Litros | código 5737



Garrafa Térmica Profissional
Inox 1.9 Litros | código 5736

CORTES AJUSTÁVEIS



JULIENNE



BATTONNET



Cortador/ Fatiador Mandoline
Profissional Ajustável | código 6282



Seca Salada
4.8 Litros
código 6499



Mandoline Profissional Cortador/Fatiador
Ajustável c/ 03 lâminas 31,5 x 9,3 cm
código 5773



Centrífuga Profissional
para Salada Manual
12 Litros | código 5770



Centrífuga Profissional
para Salada Manual
25 Litros | código 5771



RESISTENTE
ATÉ 240°
graus

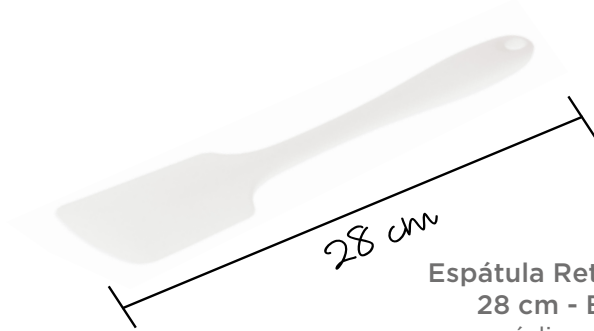

28 cm

Espátula Reta Silicone
28 cm - Branca
código 5073



36 cm

Espátula Profissional
Silicone 36 cm - Branca
código 5283



36 cm

Colher Profissional
Silicone 36 cm - Branca
código 5273

Colher Profissional Silicone
45 cm - Branca | código 5292



45 cm

Colher Profissional Silicone
45 cm - Preta | código 5290



45 cm

Espátula
Profissional
Silicone 45 cm
Branca
código 5293

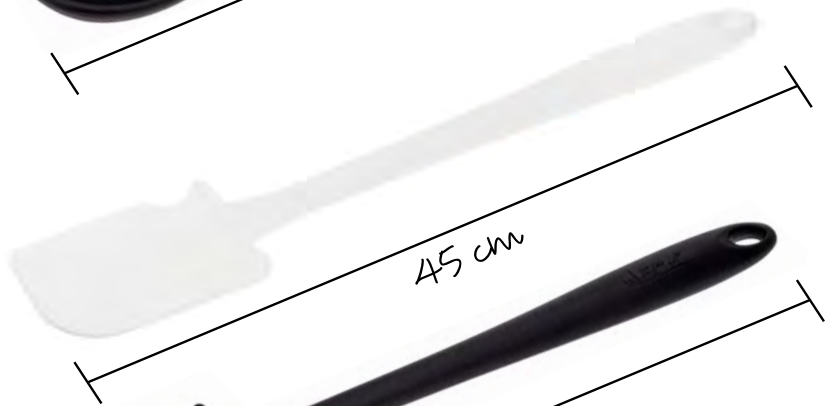

45 cm

Espátula
Profissional
Silicone 45 cm
Preta
código 5294

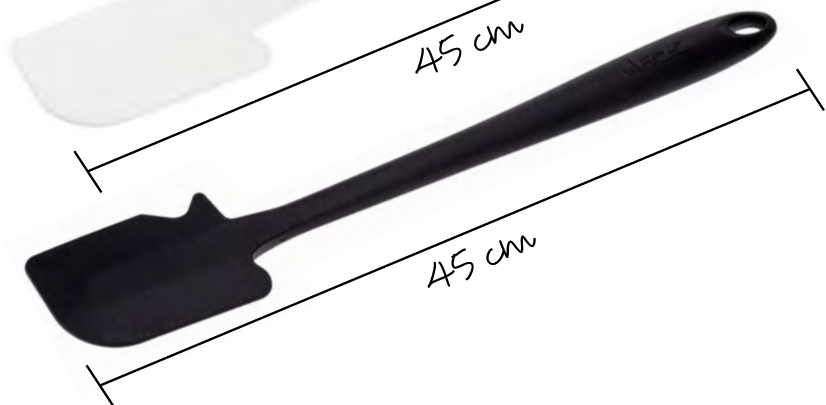

45 cm





RESISTENTE
ATÉ 240°
graus



Espátula Silicone 36 cm
Vermelha | código 5288



Espátula Silicone 36 cm
Preta | código 5289

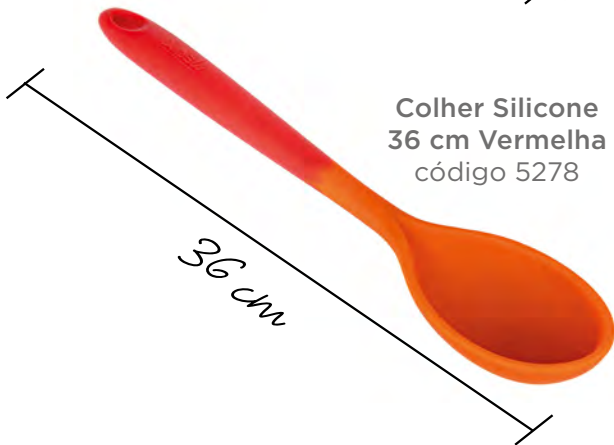

Colher Silicone
36 cm Vermelha
código 5278



Colher Silicone 36 cm
Preta | código 5279

Luva Térmica
Profissional
Silicone/ Algodão
50 cm | código 6277



Pegador Inox
Universal 30 cm
código 5228



Pegador Inox
Universal 40 cm
código 5229



Barra Magnética Preta
55 cm | código 6263

Barra Magnética Preta
33 cm | código 6253



Espremedor de Limão e
Laranja - Preto | código 6245



Espremedor de Batata
Plus | código 1609

Espremedor de Batata
Plus | código 1601





Maçarico Culinário Portátil 17 cm | código 6293



Timer Digital de Cozinha c/ Imã
LCD 6,5 x 4 cm | código 6260



Termômetro Espeto
Profissional de Aço
Inox -50° à 300°C
código 5721



Galheteiro com
Bico em Aço
Inox 250ml
código 5732

Pinça Culinária Profissional
com Serrilha Reta 20 cm Aço
Inox | código 5719



Pinça Culinária Profissional
com Serrilha Reta 30 cm Aço
Inox | código 5720





Ralador Profissional
4 Faces Aço Inox c/
Recipiente e Tampa
código 5772



Conjunto Medidores de Colheres
Inox 4 pçs: 15ml, 5ml, 2,5ml, 1.25ml
código 5693



Conjunto Medidores de Xícaras Inox
4 pçs: 250ml, 125ml, 80ml, 60ml
código 5694



Jarra Medidora
Plástica 1000ml
código 5729



Queijeira/Oreganeira
300ml - 7 x 9,5 cm Aço
Inox | código 5713



Saleiro/Pimenteiro
230ml - 6 x 8,5 cm
Aço Inox | código 5714



Polvilhador Dispenser de
Temperos 300ml c/ Alça em
Aço Inox | código 5715



Passador
Chinoy Aço
Inox 20 cm
código 5716



Passador
Chinoy Aço
Inox 24 cm
código 5717



Colher
de Arroz
Profissional
50 cm Aço Inox
código 6550



Concha
Profissional
50 cm Aço Inox
código 6551



Espumadeira
Profissional
50 cm Aço Inox
código 6552



Batedor Manual
Profissional Aço
Inox com Cabo
PP Preto 30 cm
código 6517



Batedor Manual
Profissional Aço
Inox com Cabo
PP Preto 35 cm
código 6518



Batedor Manual
Profissional Aço
Inox com Cabo
PP Preto 40 cm
código 6519



Batedor Manual
Profissional Aço
Inox com Cabo
PP Preto 45 cm
código 6520

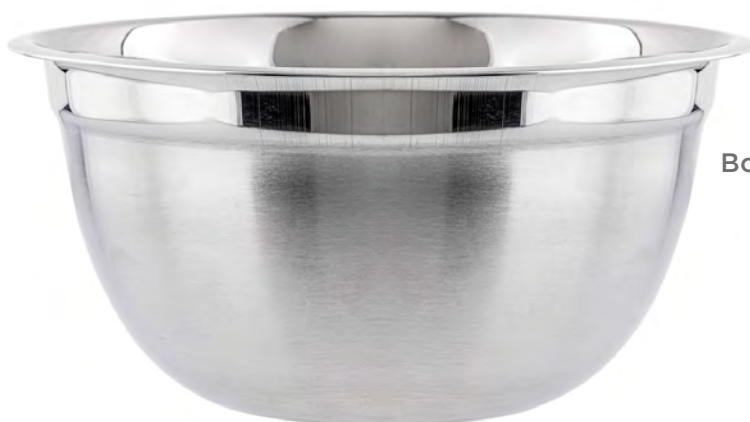

Bowl Profissional 30 cm
5900ml Aço Inox
código 6549



Bowl Profissional
14 cm 580ml Aço
Inox | código 6545



Bowl Profissional
18 cm 1230ml Aço
Inox | código 6546



Bowl Profissional 22 cm
2400ml Aço Inox | código 6547



Bowl Profissional 26 cm
4000ml Aço Inox | código 6548



Balde de Gelo 900ml Aço
Inox | código 5709



Balde para Garrafa 4.6 Litros
Aço Inox | código 5711



Bisnaga Flexível
Profissional de
1000ml
código 5681



Bisnaga Flexível
Profissional de
800ml
código 5680



Bisnaga Flexível
Profissional de
350ml
código 5679



Bisnaga Invertida
Profissional de
470ml | código 5676



Bisnaga Invertida
Profissional de
560ml | código 5677



Bisnaga Invertida
Profissional de
710ml | código 5678



Coqueteleira
Aço Inox 500ml
código 5705



Coqueteleira Boston 840ml/
28oz e Mini Tin 540ml/ 18oz
Aço Inox | código 5707



Socador de
Caipirinha/ Drinks
Aço Inox 21 cm
código 6243



Macerador Socador
Profissional Preto
25 cm ABS Preto |
código 5775



Dosador de
Bebidas 25/ 50ml
Aço Inox
código 5703



Bico Dosador de Bebida
Aço Inox 2 Peças
código 5702



Bico Dosador Dose
Certa 50ml
código 5691



Dosador 50ml Aço Inox
código 5712



Concha/ Pá para
Mantimentos e
Gelo - Plástico
Branco 22 cm
código 6271



Pegador de Gelo/Churrasco 18 cm
Aço Inox | código 5704



Abridor
Speed Opener
Profissional
18 x 4 x 1,7 cm
código 5696



Coador Strainer Profissional
Bartender Aço Inox | código 5701



Porta Comandas Profissional de Alumínio e
Esferas 60 cm | código 5695



Porta Comandas Profissional de Alumínio e Esferas 90 cm | código 5734



Colher Bailarina em Aço Inox
Coquetel e Gin 25 cm
código 5698



Colher Bailarina em
Aço Inox - Coquetel e
Gin 30 cm
código 5697



Colher Bailarina em Aço
Inox de Coquetel e Gin
com Garfo 40 cm
código 5699

Tapete Barman Mat
Runner Profissional
15 x 30 cm
código 5684



Tapete Barman
Mat Runner Profissional
60 x 8 cm | código 5686



Tapete Barman Mat Runner
Profissional 30 x 45 cm | código 5685



Porta Condimentos Profissional c/ 4
Divisórias | código 5687



Porta Condimentos Profissional c/ 6
Divisórias | código 5688



Organizador de Mesa e Bar
Profissional 24 x 15 x 11 cm
código 5690



Bordeador de Taças
Profissional | código 5689

Garrafa Store'n Pour 1 Litro



Verde
código 5651



Marron
código 5652



Branca
código 5653



Amarela
código 5654



Laranja
código 5655



Vermelha
código 5656



RESISTENTE
ATÉ 240°
graus



Forma de Gelo Esfera
60 mm em Silicone
Preto | código 5309



Forma de Gelo
24 Cubos 20 x
13 x 3 cm em
Silicone - Preto
código 5359

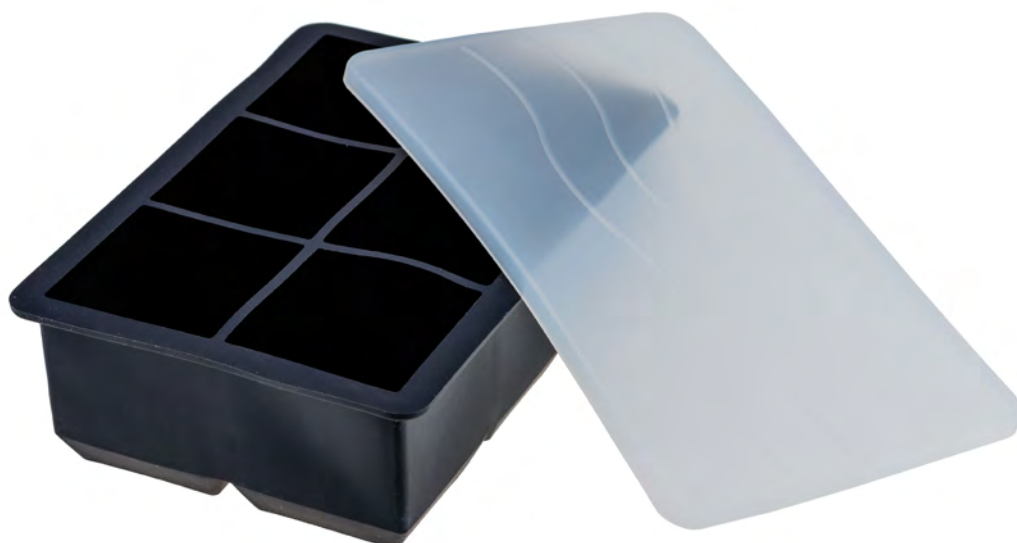

Forma de Gelo 6 Cubos 51 mm em Silicone
c/ Tampa - Preto | código 5329

*Lâmina
exclusiva
super afiada
Corte preciso
Suave no
uso



Descascador/ Fatiador
Duplo de Legumes
Plástico com Lâminas em
Aço Inox | código 6280



Descascador
de Legumes
Tipo Faca
Aço Inox
código 6261



Descascador
de Legumes
Aço Inox
código 6262



Bico Dosador
Vinagre/ Azeite 2 peças
código 6242



Tampa p/ Garrafa
2 peças
código 6241



Descascador
de Legumes
Profissional 10 cm
Aço Inox
código 6516



Saca Rolhas p/
Vinho - Preto
código 6239



Abridor de
Garrafas e Saca
Rolhas Garçom
Preto
código 6240



Saca Rolhas
2 Estágios
Preto
código 6238



Batedor Fouet
Fios de Aço Inox
28 cm Cabo Preto
código 6500



Cortador de Pizza
Lâmina em Aço Inox
Cabo Preto
código 6501

Ralador 1 Face Aço
Inox 30 cm Cabo
Preto | código 6502



Ralador Grosso 1 Face
Aço Inox Cabo Preto
código 6513

Peneira de Aço Inox
9 cm Cabo Preto
código 6504



Pá de Torta e Pizza Aço Inox
25 cm Cabo Preto | código 6503



Carretilha Corta e
Fecha Massas 17,5 cm
código 6291





Tesoura Inox p/ Cozinha 8''
20 cm | código 6215



Tesoura Inox Profissional
p/ Desossar 26 cm
código 5774



Espátula
Multiuso Aço
Inox 15 x 10 cm
código 5784



Pegador Inox Universal
39,5 cm Bico Jacaré
código 5776



Pegador Inox Universal
39,5 cm Premium
código 5777



Ralador Zester
Inox c/ Cabo Polipropileno
Preto | código 6529



Descanso de Panela Quadrado de
Silicone 17 x 17 cm - Preto | código 5349



Descanso de Panela Redondo
em Silicone Ø 18 cm
Preto | código 5339



Luva Silicone
14 cm - Preta
código 5369





Porta Condimentos/
Saleiro/Pimenteiro
Corpo de Vidro e Aço
Pintado 8 x 5 cm - Preto
código 6285

Moedor de Sal e
Pimenta Corpo de
Vidro 13 cm Moinho
em Cerâmica - Preto
código 6259



Saleiro/Pimenteiro
Corpo de Vidro
Quadrado c/ Tampa
em Aço Inox 9 x 4 cm
código 6287



Galheteiro
200ml Corpo
de Vidro e
Aço Pintado
18 x 6,5 cm - Preto
código 6286



Saleiro/ Pimenteiro Corpo de Vidro e
Aço Pintado c/ Tampa 11 x 5,5 cm - Preto
código 6284



Bandeja Redonda
Antiderrapante 40 cm
código 5761



Bandeja Oval Antiderrapante 59 x 49 cm
código 5763



Bandeja Redonda
Antiderrapante 45 cm
código 5762



Bandeja Oval Antiderrapante 68 x 56 cm
código 5764



Faca Profissional Legumes e Frutas
Forjada de 3,5" Inox | código 6534



Faca Profissional Cozinha
Forjada de 5" Inox
código 6533



Faca Profissional de Pão Forjada de 8" Inox | código 6532

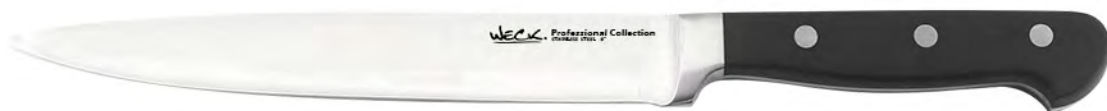

Faca Profissional Cozinha Forjada de 8" Inox | código 6531



Faca Profissional Chef Forjada de 8" Inox | código 6530



Chaira de Aço Carbono 9" c/ Cabo Preto | código 6535



**Espátula Raspadora
15 cm Profissional em
Aço Inox c/ Cabo em
Polipropileno Preto**
código 6527



**Espátula Raspadora
24 x 12 cm Profissional
em Aço Inox c/ Cabo em
Polipropileno Preto**
código 6541



**Espátula Raspadora
24 x 10 cm Profissional
em Aço Inox c/ Cabo em
Polipropileno Preto**
código 6540



**Espátula Curva Profissional
Em Aço Inox Com Cabo
Polipropileno Preto**
29,5 x 12 cm | código 6528



**Espátula Curva Profissional
em Aço Inox com Cabo
Polipropileno Preto**
29,5 x 7 cm | código 6538

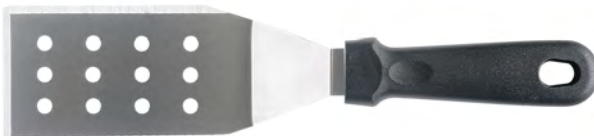

**Espátula Perfurada Curva
Profissional em Aço Inox com
Cabo em Polipropileno Preto**
29,5 x 7 cm | código 6539



**Espátula Longa Curva
Profissional em Aço Inox c/
Cabo em Polipropileno Preto**
35,5 x 7 cm | código 6536



**Espátula Perfurada Longa
Curva Profissional em Aço Inox
c/ Cabo em Polipropileno Preto**
35,5 x 7 cm | código 6537



Espátula Inox para Confeiteiro Curvada 3 x 15 cm
código 5780



Espátula Inox para Confeiteiro Curvada 3 x 25 cm | código 5779



Espátula Inox para Confeiteiro Curvada 3 x 30 cm | código 5778



Espátula Inox para Confeiteiro 3 x 15 cm
código 5783



Espátula Inox para Confeiteiro 3 x 25 cm
código 5782



Espátula Inox para Confeiteiro 3 x 30 cm | código 5781



RESISTENTE
ATÉ 240°
graus



Colher Silicone 28 cm
Cinza/Creme
código 4510



Colher Funda Silicone
28 cm Cinza/Creme
código 4504



Espátula Silicone
28 cm Cinza/Creme
código 4508



Espátula
Arredondada Silicone
29 cm Cinza/Creme
código 4512



Espátula Reta
Silicone 28 cm
Cinza/Creme
código 4514



Espátula Perfurada
Silicone 29 cm
Cinza/Creme
código 4506



Batedor Manual Fio
Silicone c/ Cabo PP
31 cm Cinza/Creme
código 4502



Concha Silicone
27 cm Cinza/Creme
código 4500



Pincel Silicone 28 cm
Cinza/Creme
código 4516



Pegador Inox c/
Ponta Silicone 23 cm
Cinza
código 4520



Pegador Inox c/
Ponta Silicone 30 cm
Cinza
código 4522



Luva Silicone e
Algodão Cinza 35 cm
código 4518



Espremedor de Limão
Creme | código 1901



Espremedor de Limão Plus
Creme | código 1905



Espremedor de
Alho Creme
código 1900



Espremedor de
Alho Plus Creme
código 1904



Martelo de Carne Creme
código 1903



Colher de Sorvete
Creme
código 1906



Espremedor de Batata Creme
código 1902



Espremedor de Limão
Cinza | código 1908



Espremedor de Limão Plus
Cinza | código 1912



Espremedor
de Alho Cinza
código 1907



Espremedor de
Alho Plus Cinza
código 1911



Martelo de Carne Cinza
código 1910



Colher de Sorvete
Cinza
código 1913



Espremedor de Batata Cinza
código 1909



RESISTENTE
ATÉ 240°
graus



Pincel
código 5089



Concha
código 5009



Colher Funda
Silicone 28 cm
código 5029



Espátula Reta
código 5079



Espátula
código 5049



Espátula
Arredondada
código 5069



Espátula Perfurada
código 5039



Colher
código 5059



Batedor Manual
código 5019



Pegador Inox c/ Ponta
em Silicone 23 cm
código 5119



Pegador Inox c/ Ponta
em Silicone 30 cm
código 5219



Luva Silicone
e Algodão
código 5099





código 1109



Espremedor de Limão Plus
código 1509



Espremedor de Alho Plus
código 1409



Espremedor de Alho
código 1009



Martelo para Carnes
código 1309



Colher de Sorvete
código 1809



Espremedor de Batata
código 1209

Espremedor
de Batata
código 1201



Espremedor de Alho
Plus | código 1401



Espremedor de Alho
código 1001



Espremedor de Limão
código 1101



Espremedor de Limão
Plus | código 1501



Martelo para Carnes
código 1301



Colher de Sorvete
código 1801





Assadeira/Travessa Alumínio
Natural 23 x 23 x 7 cm | código 3211



Assadeira/Travessa Alumínio
Natural 23 x 15 x 7 cm
código 3201



Assadeira/Travessa
Alumínio Natural
38 x 15 x 7 cm | código 3221



Assadeira/Travessa Alumínio
Natural 38 x 23 x 7 cm
código 3231

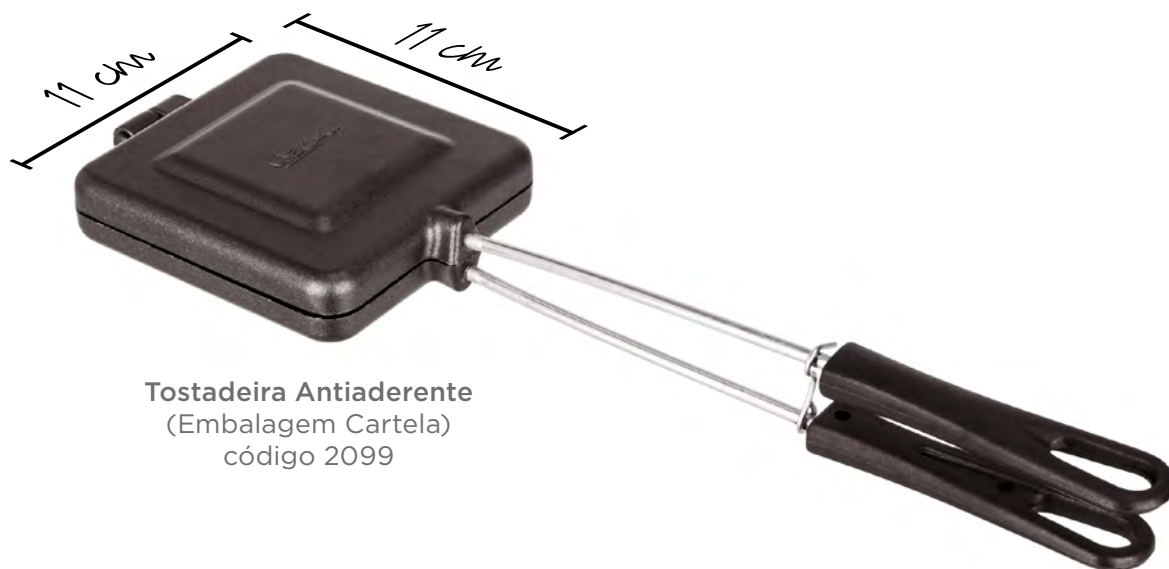

Tostadeira Antiaderente
(Embalagem Cartela)
código 2099

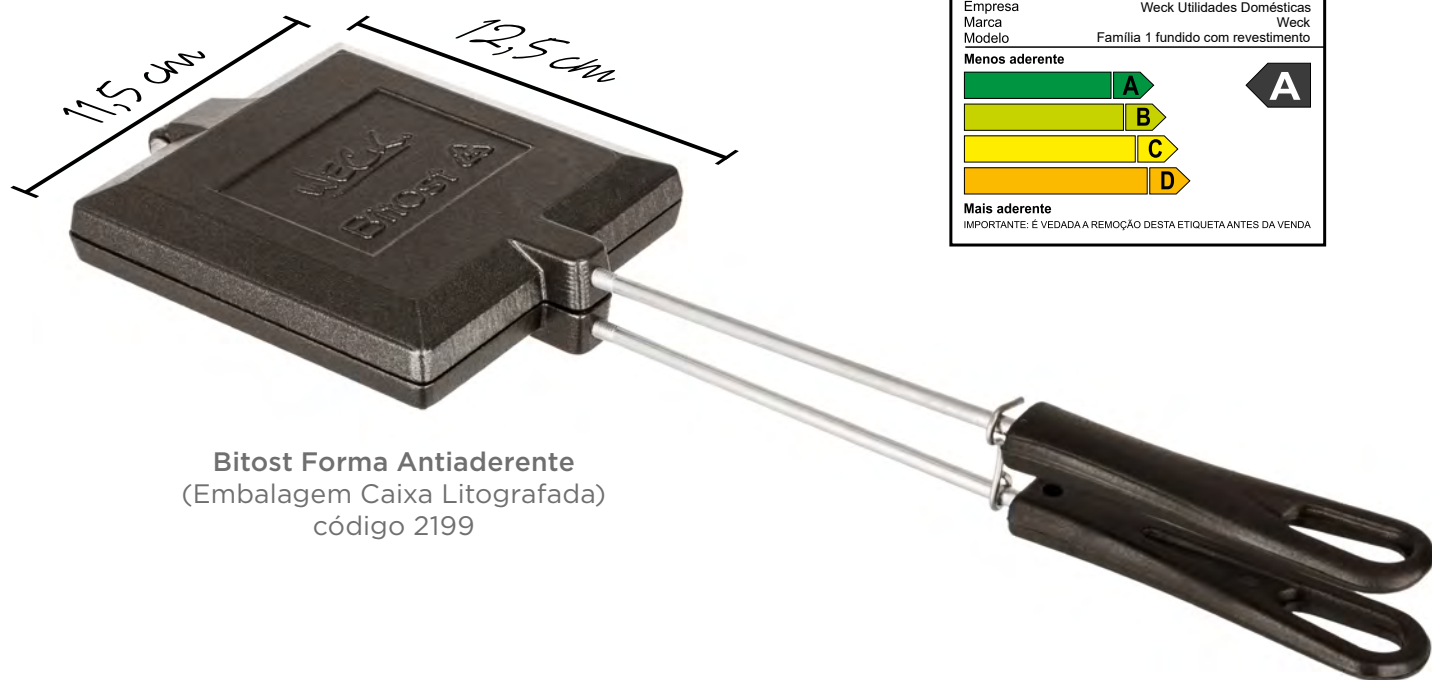

Bitost Forma Antiaderente
(Embalagem Caixa Litografada)
código 2199

Aderência		Segurança
		TS DLP 8104 Compulsório
REGISTRO INMETRO 006188/2021		
Empresa	Weck Utilidades Domésticas	
Marca	Weck	
Modelo	Família 1 fundido com revestimento	
Menos aderente		
	A	
	B	
	C	
	D	
Mais aderente		
IMPORTANTE: É VEDADA A REMOÇÃO DESTA ETIQUETA ANTES DA VENDA		

LANÇAMENTOS FISPA 2026



WECK.



Porta Sachê 8,3 x 6,0 x 4,5cm
SKU:6675



Tigela Redonda Estriada
11,5cm - 370ml
SKU:6674



Prato de Sobremesa 20 x 2cm
SKU:6667



Prato Raso 25,5 x 2,3cm
SKU:6668



Barco Sushi-Sashimi 41,6 x 18,2 x 6,5cm
SKU:6669

100%
MELAMINA



Não usar no micro-ondas, na chama direta ou no forno
Suporta de -20°C a +70°C por até 2hrs





Travessa Retangular Funda 40,5 x 27,6 x 5,7 cm
SKU:6670



Travessa Retangular
35 x 24 x 2,1 cm
SKU:6672



Travessa Retangular
25 x 17 x 1,6 cm
SKU:6673



Saladeira Estriada 28 x 9cm
2,5L
SKU:6665



Prato para Bolo com pé 35,5 x 12cm
SKU:6671

100%
MELAMINA



Não usar no micro-ondas, na chama direta ou no forno
Suporta de -20°C a +70°C por até 2hrs





Porta Shoyo 10 x 6,5 x 2,5 cm
50ml
SKU:6690



Finger Food Folha
9,5 x 7,8 x 3,2 cm - 62ml
SKU:6687



Finger Food Quadrado
8,8 x 8,4 x 3,5 - 90ml
SKU:6689



Tigela Redonda com Aba
13,8 x 11 x 4,5cm - 150ml
SKU:6688



Prato de Sobremesa Preto 21 x 2,2cm
SKU:6676



Prato Raso Preto 26,5 x 2,5cm
SKU:6677



Tigela Redonda Preta 15 x 7 cm
600ml
SKU:6678



Tigela Redonda Estriada
15 x 6,7cm - 600ml
SKU:6686



Tigela Redonda Estriada
11 x 5,6cm - 260ml
SKU:6685

100%
MELAMINA



Não usar no micro-ondas, na chama direta ou no forno
Suporta de -20°C a +70°C por até 2hrs





Travessa Tipo Telha 25,3 x 13 x 3 cm
SKU:6682



Travessa Tipo Telha 20 x 10,5 x 3 cm
SKU:6683

Travessa Sushi/Sashimi
23,7 x 7,5 x 1,5cm
SKU:6684



Meia Lua com Porta Shoyo
27 x 11,5 x 2,5
SKU:6680

Prato Quadrado com Porta Shoyo
17,5 x 17,5 3,5 cm
SKU:6681



Travessa Retangular Sushi/Sashimi
28,5 x 12 x 1,5
SKU:6679

100%
MELAMINA



Não usar no micro-ondas, na chama direta ou no forno
Suporta de -20°C a +70°C por até 2hrs





Rechaud Retangular
com Fogareiro 1/1
SKU:6598



Rechaud Retangular
com Fogareiro 1/2
SKU:6599



Resistência Para Rechaud
220v
SKU:6597



Cuba Inox 1/1 Perfurada
65mm
SKU:6589



Cuba Inox 1/2 com Alça
65mm
SKU:6590



Tampa Cuba 1/9 Inox
SKU:6588

Cuba Inox 1/9

SKU	TAMANHO
6586	100MM
6587	65MM



Carrinho de Serviço 3 Andares
81 x 43,5 x 91cm

SKU:5768



Carrinho de Serviço 3 Andares
102 x 50 x 96cm

SKU:5769





WECK.

www.weckud.com.br

atendimento@weckud.com.br

Fone: 55 11 2022 5023



facebook.com/weckoficial



[@weckud](https://instagram.com/@weckud)